

4.3.1 “BAU” Meter Wiring Diagrams

The following Meter Wiring Diagrams provide details of the wiring of metering on “New Connections” and existing “Add/Alt” customer installations undertaken as Business as Usual (BAU) activities, and comply with the CitiPower and Powercor Tariff rules introduced in January 2010. Those rules removed dedicated circuit load control tariffs such as CDS (CitiPower) and DD1, HW, CS (Powercor), and flat rate and other General Power and Light tariffs such as C1R, C2R (CitiPower) and D1, D2 (Powercor) for “New”, “Add/Alt” and “Tariff Change” installations, and require those installations to be connected to time of use tariffs such as C3R in CitiPower or D3 in Powercor.

Load Switching – New Connections.

New Connection customers with single phase installations will still be provided with a switching service for eligible single phase off-peak hotwater units up to 30A, inclusive of boost tails (if permitted by the Retailer).

New Connection customers with multiphase installations will need to provide their own timer and load control within the customer’s own switchboard.

Load Switching – Existing Customer “Adds/Alt” (including Tariff Changes)

Existing customers with hot water controlled load in single phase installations will still be provided with a switching service for eligible single phase off-peak hotwater units up to 30A, inclusive of boost tails (if permitted by the Retailer).

Existing customers with hot water controlled load in multiphase installations will still be provided with a switching service for eligible single phase off-peak hotwater units up to 30A, however any boost tails will need to be re-wired to the customers own switchboard, as will any multiphase hotwater systems.

VSIR Figures

The following figures in the Victorian Service and Installation Rules will no longer apply to new or altered connections in the CitiPower and Powercor Network areas from 1st January 2010. Figures 8.9, 8.12, 8.13, 8.14, 8.17.

Document Administrator: Metering Standards Manager - AMI Services	Section 4.3.1 Meter Wiring Diagrams	Nominated Approver: Customer Connection Policy Manager - Electricity Networks
Document no: 06-M021	Issue no: 2 Issue date: 21/11/2011	Page 1 of 9

Powercor Specific Requirements –Climate Saver – withdrawn

The following Powercor Specific Requirements drawings previously published on the Powercor web site will no longer apply to new connections, or alterations and additions in the Powercor Network areas from 1st January 2010. CS-1, CS-2, CS-3, CS-4, CS-5, CS-6.

CitiPower / Powercor Specific Requirements – from January 2010

The following Specific Requirements apply to New Connections and Add/Alt Customers within CitiPower and Powercor Network areas from 1st January 2010, refer to VSIR figures 8.6 and 8.8 for relevant meter panel layouts.

MWD-1, MWD-2, MWD-3 and MWD-4 are available to all “New”, “Add/Alt” and “TFiT” customers in the CitiPower and Powercor Network areas.

- MWD – 1** Single phase 1 Element Meter
- MWD – 2** Single phase 1 Element Meter with load contactor
- MWD – 3** Three phase Meter (installed as 2 phase)*
- MWD – 4** Three phase Meter

MWD-5 and MWD-6 are only available to existing customers with controlled load single phase hot water undertaking “Add/Alt” or tariff changes including “TFiT”* in the CitiPower and Powercor Network areas.

- MWD – 5** Three phase Meter (installed as 2 phase)* with load contactor
- MWD – 6** Three phase Meter with load contactor

Bi-directional Metering for Embedded Generation

All bi-directional metering in CitiPower / Powercor is provided as net metering, gross metering for embedded generation is not provided.

PFIT and TFIT Metering, and Load Control

The Premium Feed in Tariff (**PFIT**) will be closed to new customers and replaced with the Transitional Feed in Tariff (**TFIT**) from 1 January 2012, both of these feed in tariffs are limited to customers with solar systems below 5kW capacity and require single element – single meter installations as per **MWD-1 to MWD-6** and move to Time of Use Network consumption tariffs.

Document Administrator: Metering Standards Manager - AMI Services	Section 4.3.1 Meter Wiring Diagrams	Nominated Approver: Customer Connection Policy Manager - Electricity Networks
Document no: 06-M021	Issue no: 2 Issue date: 21/11/2011	Page 2 of 9

Existing customers applying for connection to TFIT with complex or multiple metering, including existing dedicated circuit controlled loads such as Climate Saver, slab heating or heat banks, or multi-phase off-peak hotwater systems, will need to engage a Registered Electrical Contractor to re-wire those circuits back to the customers Main Switch Board for supply from the general power circuits, and to install customer owned timer/load control devices.

Customers with existing single phase off-peak hot water systems under 30A load capacity, including those with two element metering, will continue to have that load controlled by the metering installation during the off-peak period of the ToU tariff.

All TFIT applications will have existing metering replaced with a bi-directional AMI single element – single meter to comply with Net instantaneous metering requirements, and will move to Time of Use Network consumption tariffs.

SFIT Metering, and Load Control

The Standard Feed in Tariff (**SFIT**) will be closed to new customers with solar systems below 5kW and qualifying for connection to TFIT from 1 January 2012. SFIT applications are permitted to remain on their existing Network consumption tariffs and to retain existing load control arrangements via the metering.

SFIT applications will have existing metering replaced with a “like for like” bi-directional AMI metering installation to maintain access to existing tariffs and those existing load control arrangements.

Note 1: As “TFIT” is replacing “PFIT” from 1 January 2012 – references to PFIT in the following Meter Wiring Diagrams is to be taken to also mean TFIT.

Note 2: “Like for like” metering installations for SFIT are not covered by the following Meter Wiring Diagrams, other than for New Connections.

Note 3: A “2” phase AMI Meter does not exist, and installations of 3 Phase meters at 2 phase premises shall be installed by Distributor Metering Personnel in accordance with the “Installation of “Two Phase” Interval Meters Policy in section 4.1 of the Connection Standards Manual with reference to Meter Terminal Drawing AMT-4.

Note 4: “New Connection” and “Adds/Alt” Installations are to be connected in accordance with the current Victorian Service and Installation Rules.

Document Administrator: Metering Standards Manager - AMI Services	Section 4.3.1 Meter Wiring Diagrams	Nominated Approver: Customer Connection Policy Manager - Electricity Networks
Document no: 06-M021	Issue no: 2 Issue date: 21/11/2011	Page 3 of 9

METER WIRING DIAGRAM

MWD – 1 Single Phase 1 Element AMI Meter

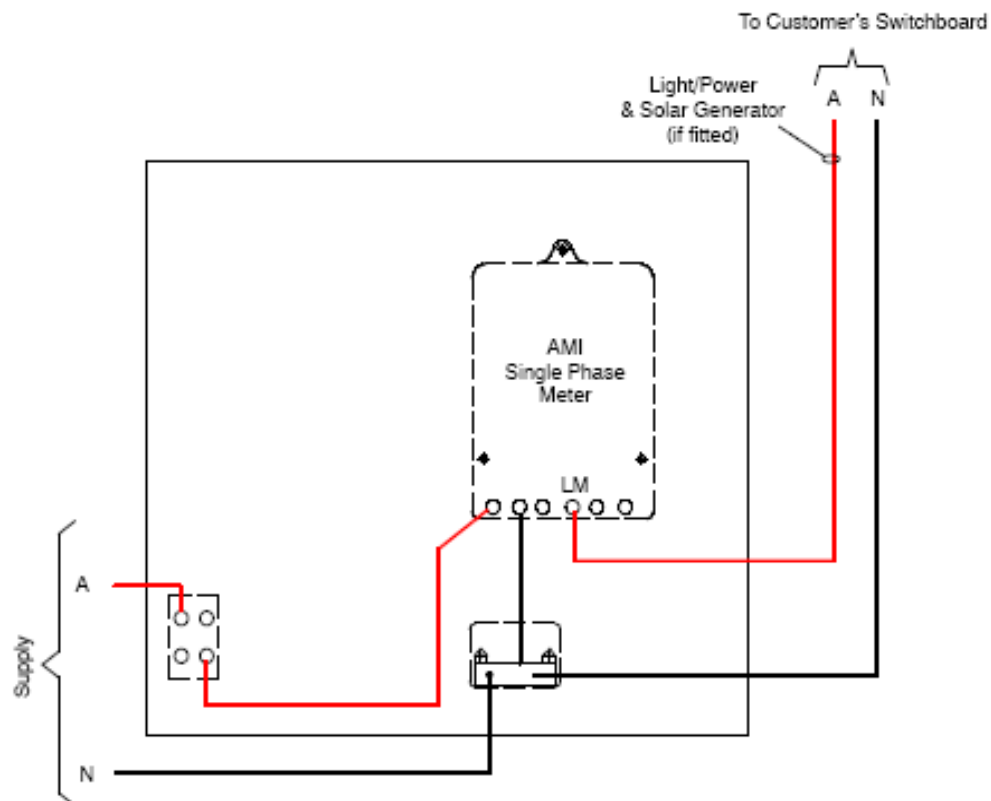

Notes

1. Available to all "New", "Add/Alt", and "PFIT" customers in Citipower and Powercor
2. Refer to VSIR Figure 8.6 for meter panel layout
3. Solar Generator (if fitted) connected to Light/Power circuits in customer's main switch board
4. Meter panel fuse not required where an arial service line is provided
5. Refer figure AMT-1 for Meter Terminal Drawing

Document Administrator: Metering Standards Manager - AMI Services	Section 4.3.1 Meter Wiring Diagrams	Nominated Approver: Customer Connection Policy Manager - Electricity Networks
Document no: 06-M021	Issue no: 2 Issue date: 21/11/2011	Page 4 of 9

METER WIRING DIAGRAM

MWD – 2 Single Phase 1 Element AMI Meter with contactor

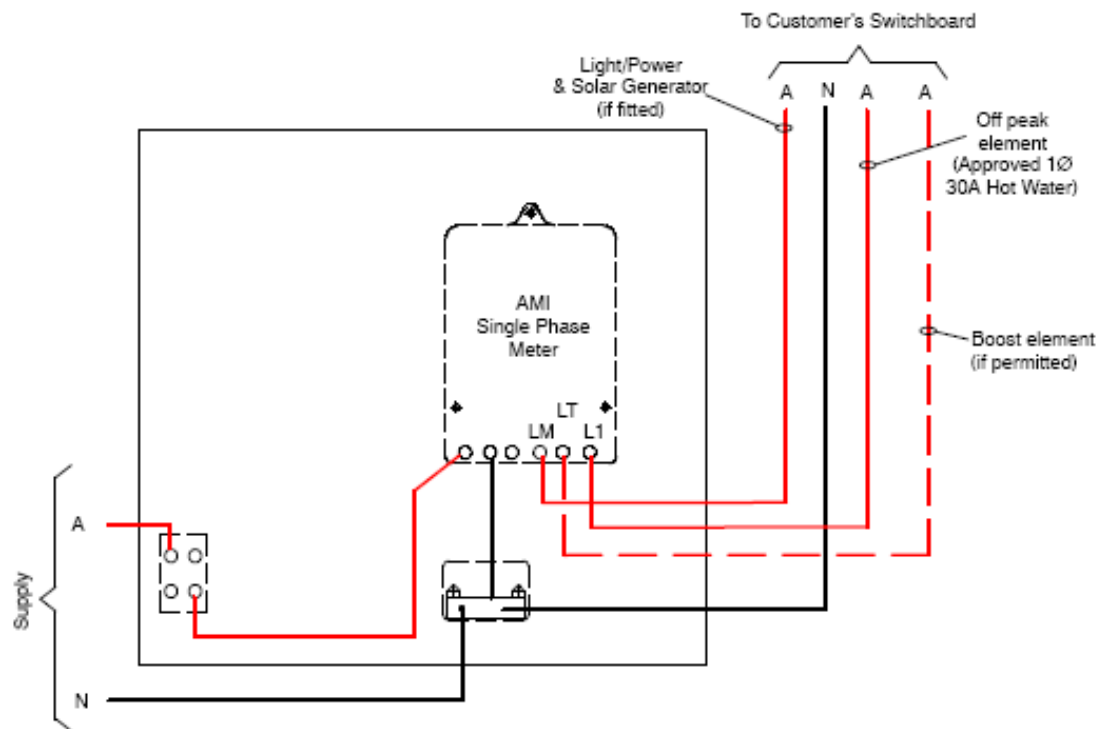

Notes

1. Available to all "New", "Add/Alt" and "PFIT" customers in Citipower and Powercor
2. Refer to VSIR Figure 8.6 for Meter Panel Layout
3. Single Phase Approved Off-peak storage Hot Water Service may be connected to meter
4. Boost Element (if permitted by retailer) may be connected to Meter
5. Solar Generator (if fitted) connected to Light/Power circuits in customer's main switch board
6. Meter panel fuse not required where an arial service line is provided
7. Controlled load current must not exceed 30 Amperes
8. Refer figure AMT-2 for Meter Terminal Drawing

Document Administrator: Metering Standards Manager - AMI Services	Section 4.3.1 Meter Wiring Diagrams	Nominated Approver: Customer Connection Policy Manager - Electricity Networks
Document no: 06-M021	Issue no: 2 Issue date: 21/11/2011	Page 5 of 9

METER WIRING DIAGRAM

MWD – 3 Three Phase AMI Meter (as 2 Phase)

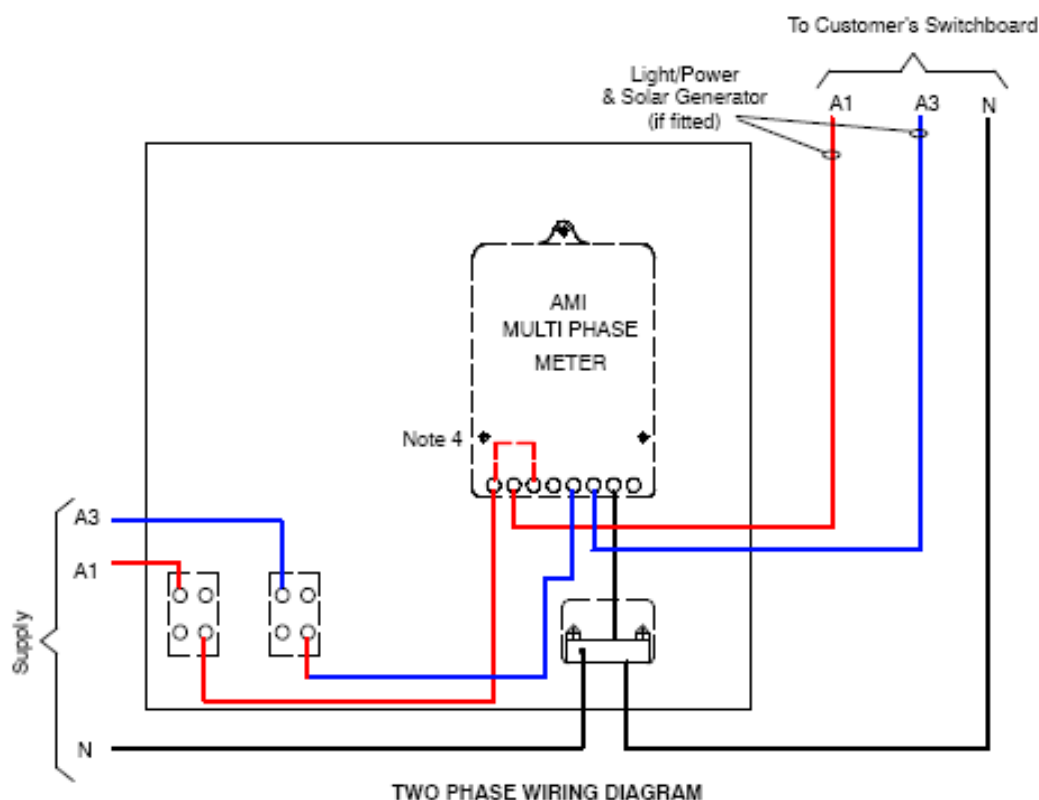

Notes

1. Available to all "New", "Add/Alt" and "PFIT" customers in CitiPower and Powercor
2. Refer to VSIR Figure 8.8 for Meter Panel Layout
3. Unused phase on 2 Ph supply to be bridged at potential terminal of 3 Ph meter
4. Unused Phase:
 Distributor metering personnel to install 2.5mm² stranded cable marked --- as per figure AMT-4
5. Solar Generator (if fitted) connected to Light/Power circuits in customer's main switch board
6. Meter panel fuses not required where an arial service line is provided
7. Refer figure AMT-4 for Meter Terminal Drawing

Document Administrator: Metering Standards Manager - AMI Services	Section 4.3.1 Meter Wiring Diagrams	Nominated Approver: Customer Connection Policy Manager - Electricity Networks
Document no: 06-M021	Issue no: 2 Issue date: 21/11/2011	Page 6 of 9

METER WIRING DIAGRAM

MWD – 4 Three Phase AMI Meter

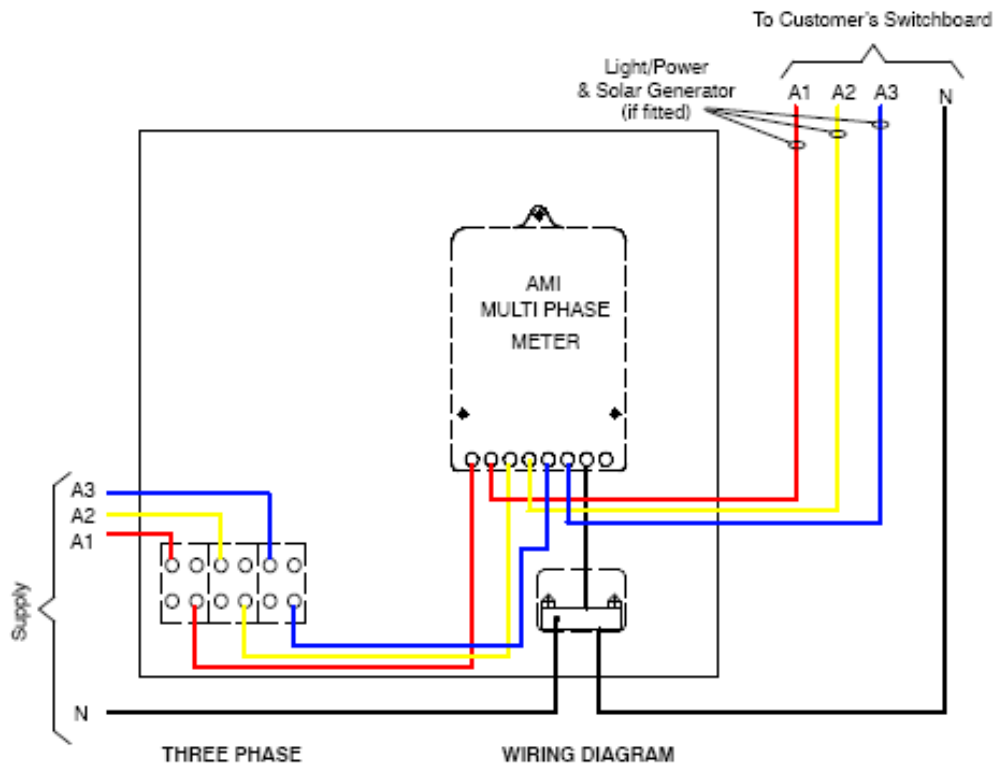

Notes

1. Available to all "New", "Add/Alt" and "PFIT" customers in CitiPower and Powercor
2. Refer to VSIR Figure 8.8 for Meter Panel Layout
3. Solar Generator (if fitted) connected to Light/Power circuits in customer's main switch board
4. Meter panel fuses not required where an arial service line is provided
5. Refer figure AMT-6 for Meter Terminal Drawing

Document Administrator: Metering Standards Manager - AMI Services	Section 4.3.1 Meter Wiring Diagrams	Nominated Approver: Customer Connection Policy Manager - Electricity Networks
Document no: 06-M021	Issue no: 2 Issue date: 21/11/2011	Page 7 of 9

METER WIRING DIAGRAM

MWD – 5 Three Phase AMI Meter (as 2 Phase) with contactor

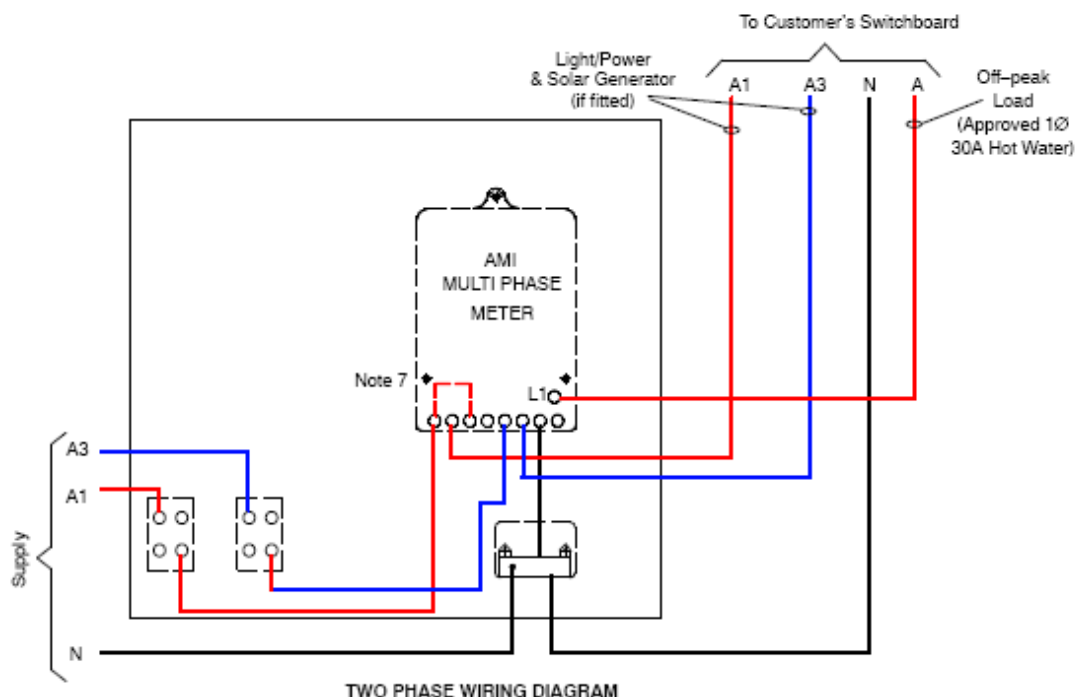

Notes

1. Only available to "existing customers with Hot Water Controlled Load", in CitiPower and Powercor, undertaking "Add/Alt", or Tariff Change, including "PFIT"
2. Single Phase Approved Off-Peak Storage Hot Water Service may be connected to meter
3. Boost Element (if fitted) must be wired to customer's switchboard
4. Refer to VSIR Figure 8.8 for meter panel layout
5. Switching service will require contacting meter to be installed
6. Unused phase on 2 Ph supply to be bridged at potential terminal of 3 Ph meter
7. Unused Phase:
Distributor metering personnel to install 2.5mm² stranded cable marked --- as per figure AMT-5
8. Solar Generator (if fitted) connected to Light/Power circuits in customer's main switch board
9. Meter panel fuses not required where an arial service line is provided
10. Controlled load current must not exceed 30 Amperes
11. Refer figure AMT-5 for Meter Terminal Drawing

Document Administrator: Metering Standards Manager - AMI Services	Section 4.3.1 Meter Wiring Diagrams	Nominated Approver: Customer Connection Policy Manager - Electricity Networks
Document no: 06-M021	Issue no: 2 Issue date: 21/11/2011	Page 8 of 9

METER WIRING DIAGRAM

MWD – 6 Three Phase AMI Meter with contactor

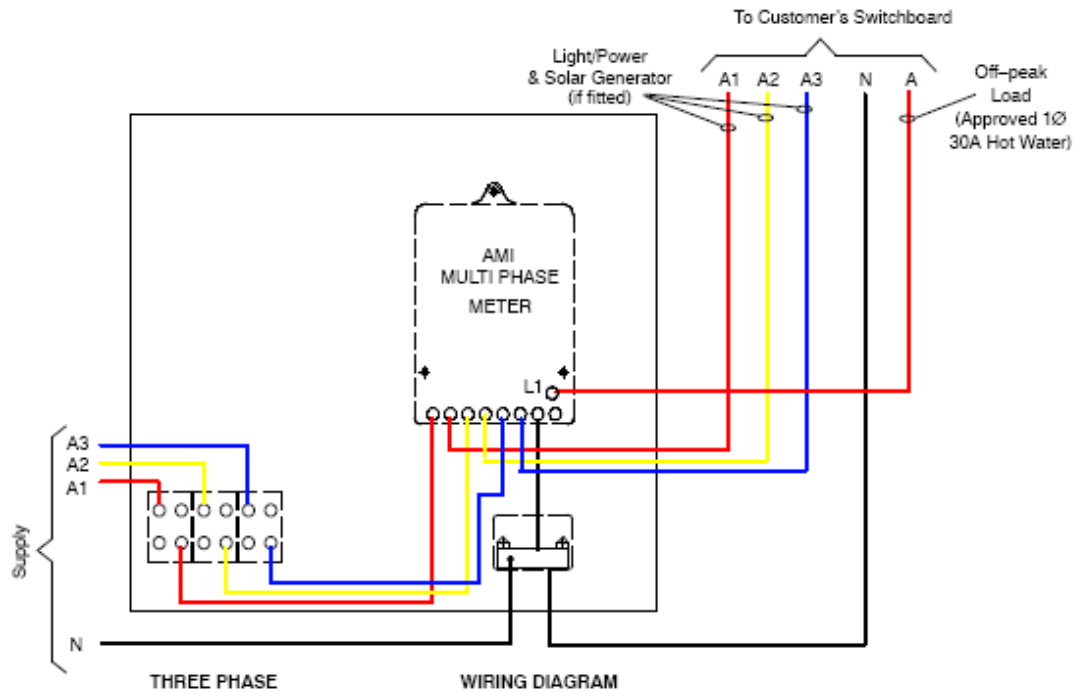

Notes

1. Only available to "existing customers with Hot Water Controlled Load", in CitiPower and Powercor, undertaking "Add/Alt", or Tariff Change, including "PFIT"
2. Single Phase Approved Off-Peak Storage Hot Water Service may be connected to meter
3. Boost Element (If fitted) must be wired to customer's switchboard
4. Refer to VSIR Figure 8.8 for meter panel layout
5. Switching service will require contacting meter to be installed
6. Solar Generator (if fitted) connected to Light/Power circuits in customer's main switch board
7. Meter panel fuses not required where an arial service line is provided
8. Controlled load current must not exceed 30 Amperes
9. Refer figure AMT-7 for Meter Terminal Drawing

Document Administrator: Metering Standards Manager - AMI Services	Section 4.3.1 Meter Wiring Diagrams	Nominated Approver: Customer Connection Policy Manager - Electricity Networks
Document no: 06-M021	Issue no: 2 Issue date: 21/11/2011	Page 9 of 9