

# Memorandum

---

**To** All Construction Service Providers, Resource Managers/Coordinators, Network Compliance Auditors

**Copy** All Customer Project Managers, C Jenkins, J Baker

**Date** 30 June 2005

**Subject** **Network Compliance – Underground Estates**

---

This memorandum has been prepared following a number of recent issues and incidents in regard to the tie in of underground estates and the future proposal regarding authorisation of service providers to complete the tie in of their green field work.

A number of improvements in the existing process have been considered and are now implemented from the date of this memorandum. The changes cover, testing, reporting, rationalisation of forms/report sheets and the handover of underground projects for tie in.

Details of the changes/updates are included in this memorandum, can also be accessed through the Powercor standards internet site. (from next week)

- **Personnel Safety and Services Clearance** (Document No PCA4143.D10) has been revised, additional information is now required, including a description of works/assets, verification of 'as built' drawings and check boxes indicating the appropriate test forms included - (*attachment a*)
- **High Voltage Cable Test Report** – the only accepted form is the extract out of Powercor Standard CC10, test items 1,2,3, and 4 (1min reading) must be completed - (*attachment b*)
- **Low Voltage Cable Test Report** – the only accepted form is the Powercor Standard CC091 -(*attachment c*)
- **Public Lighting Polarity Test Report** has been revised to include the Earth Test Report - Powercor Form 03-F570, this is the only form to be used - (*attachment d*)  
*Note: All public lighting columns must be listed.*
- **LV UG Cable ends** - all Low Voltage cables not terminated are now to be insulated sealed as per the Powercor Standard GS351, this also allows for effective testing of cables -(*attachment e*)
- **Cable Location For Future Tie-in** - all underground cables that are not terminated but are prepared for a future tie-in should be identifiable by the installation of a standard service pit located 100mm past the end of the cable on the same offset, the pit should be installed similar to comply with the standard GS201- (*attachment f*)

- **Installation of UG Cables For Tie-in** - all new cables required to be tied in to an existing cable should be installed in a manner the overlaps the existing cable by sufficient length to enable the joint to be completed. The constructor must locate existing cable end, lay the new cable over the top of the cover slab and then back fill the trench, note the pit is to be used for identification of the location of the existing cable end. *-(attachment g)*  
Note: The MOC's / No Go Zone processes must be adhered to prior to undertaking any excavation.
- **Labelling of Cables for Tie-in** - all cable ends are to be labelled during construction i.e. cable ends capped and buried in the ground. Suitable cable labelling can include permanent white/yellow paint marker or plastic label attached to the cable by means of cable tie; labels are to indicate the cable circuit details. *-(attachment h)*
- **Distribution Plant Transformers Test Report** – these report forms should be used to record the plant details, continuity and insulation tests, earth tests and a final checks, they are the only accepted forms and are included in the Powercor Standard CB011.  
Note: All transformers must have a continuity and insulation test completed and recorded.
- **Alterations / Additions to Assets** – the only accepted form is the Powercor Standard 06-F855 *-(attachment i)*  
Note: generally for overhead projects

Should you have further queries please contact Les Ferris ph. 53272404 or Graeme Davenport ph. 53272238

**Les Ferris**  
**Network Compliance Manager**  
**Ph. 0419 893 082**  
[lferris@powercor.com.au](mailto:lferris@powercor.com.au)

(attachment a)

**Powercor Australia Ltd**  
(ABN 89 064 651 109)

<b>PERSONNEL SAFETY AND ELECTRICAL ASSET CLEARANCE</b>
--

Further to the request for Tie-in works related to the following project:

Project Name			
Customer's Name			
Powercor Network Number		Powercor Reference	

Description of Works/Assets

**I confirm the following details:**

Drawing No. 'As Built'		Verified by	
------------------------	--	-------------	--

Date of Tie-in			
Nominated audits undertaken by			
Completed on (date)	NW Staged Compliance Audit		
	Final NW Compliance		

**Tick the relevant boxes to indicate report/form attached**

- |  |  |
|--|--|
| <input type="checkbox"/> Low Voltage Test Report –CC091                        | <input type="checkbox"/> High Voltage Test Report (sections 1, 2, 3, 4) –CC101 |
| <input type="checkbox"/> Distribution Plant Transformers Test Report –CB011    | <input type="checkbox"/> Alterations/Additions to Assets - 06-F855             |
| <input type="checkbox"/> Public Lighting Polarity / Earth Test Report –03-F570 | <input type="checkbox"/> Network Staged Audit Checklist –12-F731               |
| <input type="checkbox"/> Final Network Audit Report –12 F-730                  |  |

**I declare and understand that:**

- All work excluding the Tie In is complete.
- The project has been designed and built to the approved Powercor/CitiPower standards and specifications
- The installed electrical apparatus must now be treated as alive and that any further work required on this apparatus shall only be carried out by authorised Powercor Australia employees.

Signed		Printed Name	
Position		Company	
Date			

Failure to lodge this form a minimum of five (5) business days prior to the nominated Tie In date will result in planned Tie In works being re-scheduled and an additional Tie In Fee being charged to the Developer.

(attachment b)

WARNING: Printed copies of this document MAY NOT BE THE LATEST. The most up-to-date version is located on the Intranet.

Place this completed document in the construction file

CC101

## High Voltage XLPE, EPR and Hybrid PILC/XLPE Cable Commissioning Test Report

Job Title \_\_\_\_\_  
Cable Circuit Details \_\_\_\_\_  
Test Instrument Model \_\_\_\_\_ Instrument No. \_\_\_\_\_  
Test Instrument Model \_\_\_\_\_ Instrument No. \_\_\_\_\_  
Tested by \_\_\_\_\_ Date \_\_\_\_\_  
Cable Type Details \_\_\_\_\_

Tests to be undertaken as outlined in Test Procedure Flow Chart

1. All circuits identified and labelled \_\_\_\_\_ Yes / NO  
2. Continuity / Phase Sequence Tests passed \_\_\_\_\_ Yes / No

### 3. Sheath Integrity Test

SHEATH INTEGRITY TEST 1 KV	
Screen Wires to Earth	Resistance
Red	MΩ
White	MΩ
Blue	MΩ

### 4. Insulation Resistance Test

INSULATION RESISTANCE TEST 5KV				
Phase to Screen - All Cables	1 min. reading	10 min. reading	Polarisation Index	Phase Comparison
Red	MΩ	MΩ		
White	MΩ	MΩ		
Blue	MΩ	MΩ		

### 5. VLF Test

Phase to screen
Pass
Fail

Screen Wires to Earth - must be greater than or equal to 1 MW



Polarisation Index - ten minute reading / one minute reading  $\geq 2$ .

Phase Comparison - variation between phases must be less than 25%.

Note: All Constructors must complete items 1,2,3,4 and 5 as per flow chart.

Comments \_\_\_\_\_

Signed: \_\_\_\_\_ Date: \_\_\_\_\_ Test Result (Pass / Fail)

	Commissioning Standard		31 May 05 Page 1 of 2	CC101
	High Voltage XLPE, EPR, PILC/XLPE Cable Commissioning Test Report		Administrator: <i>J. J. J.</i> PAL Tech Approval: <i>P. B.</i> CP Tech Approval: <i>W. L.</i>	

(attachment c)

WARNING: Printed copies of this document MAY NOT BE THE LATEST. The most up-to-date version is located on the Intranet.

Place this completed document in the construction file

CC091

### Low Voltage Cable Test Report

Job Title \_\_\_\_\_

Test Instrument Model \_\_\_\_\_ Instrument No. \_\_\_\_\_

Test Instrument Model \_\_\_\_\_ Instrument No. \_\_\_\_\_

Tested by \_\_\_\_\_ Date \_\_\_\_\_

CIRCUIT DETAILS (Put circuit name in box below)				
	1.	2.	3.	4.

PHASE TO PHASE				
Red to White	MΩ	MΩ	MΩ	MΩ
White to Blue	MΩ	MΩ	MΩ	MΩ
Blue to Red	MΩ	MΩ	MΩ	MΩ

ALL PHASES TESTED TO NEUTRAL - NEUTRALS DISCONNECTED				
Red to Neutral	MΩ	MΩ	MΩ	MΩ
White to Neutral	MΩ	MΩ	MΩ	MΩ
Blue to Neutral	MΩ	MΩ	MΩ	MΩ

ALL CONDUCTORS TESTED TO EARTH - NEUTRALS DISCONNECTED				
Red to Earth	MΩ	MΩ	MΩ	MΩ
White to Earth	MΩ	MΩ	MΩ	MΩ
Blue to Earth	MΩ	MΩ	MΩ	MΩ
Neutral to Earth	MΩ	MΩ	MΩ	MΩ

CONTINUITY AND PHASE IDENTIFICATION TEST	
Phase	Checked
Red	
White	
Blue	

FINAL TEST - NEUTRALS CONNECTED				
Red to Neutral	MΩ	MΩ	MΩ	MΩ
White to Neutral	MΩ	MΩ	MΩ	MΩ
Blue to Neutral	MΩ	MΩ	MΩ	MΩ

All circuits identified and labelled Yes  No

Comments \_\_\_\_\_

Signed: \_\_\_\_\_ Date: \_\_\_\_\_

	Commissioning Standard		31 May 05 Page 1 of 2	CC091
	<b>Low Voltage Cable Test Report</b>		Administrator: <i>J. Inghill</i> PAL Tech Approval: <i>P. Banks</i> CP Tech Approval: <i>W. Lewis</i>	



(attachment e)

**GS351**

**Insulated End Assembly—  
Heatshrink**

LV Mains Cable	Cores
120mm <sup>2</sup> 3/Core	A
185mm <sup>2</sup> 4/Core	B
240mm <sup>2</sup> 4/Core	C

**Scope**

This standard provides information for selecting and ordering LV heatshrink insulated ends for sealing unused LV mains cables.

**Standard References**

GS001 Underground LV Mains and Service—  
General Information

GS011 Underground LV Mains and Service—Cable

**Notes**

1. Figure 1 illustrates a typical end cap assembly for 4-core LV mains cable. A single layer of putty tape should be applied over the cable cut to protect the end caps from sharp edges.

Table 1 - Component Assemblies

No.	Standard	Description
1	DY411	Sleeve, End Cap, Heatshrink, 100/50mm (Outer End Cap)
2	DY411	Sleeve, End Cap, Heatshrink, 35/15mm (Inner End Cap)
3	DY401	Sleeve, Heatshrink, Black, 115/30 x 600mm Long
4	DY911	Putty, Insulating, Tape Form

<b>Distribution Construction Standard</b> <small>Administrator: Tech. Approval:</small>	<b>Insulated End Assembly —Heatshrink</b>	<b>GS351</b> <small>27 Sep 02 Page 1 of 2</small>	
--	---	--	---

**GS351**

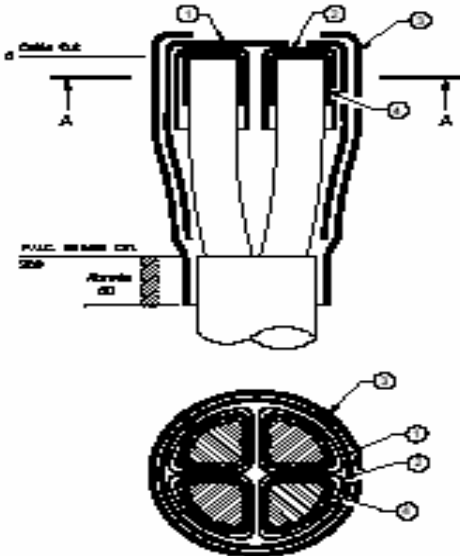

Section A-A

Figure 1 - Insulated End Assembly - 4/4Core Cable

	<b>GS351</b> <small>27 Sep 02 Page 2 of 2</small>	<b>Insulated End Assembly —Heatshrink</b>	<b>Distribution Construction Standard</b> <small>Administrator: Tech. Approval:</small>
--	--	---	--

**(attachment f)**

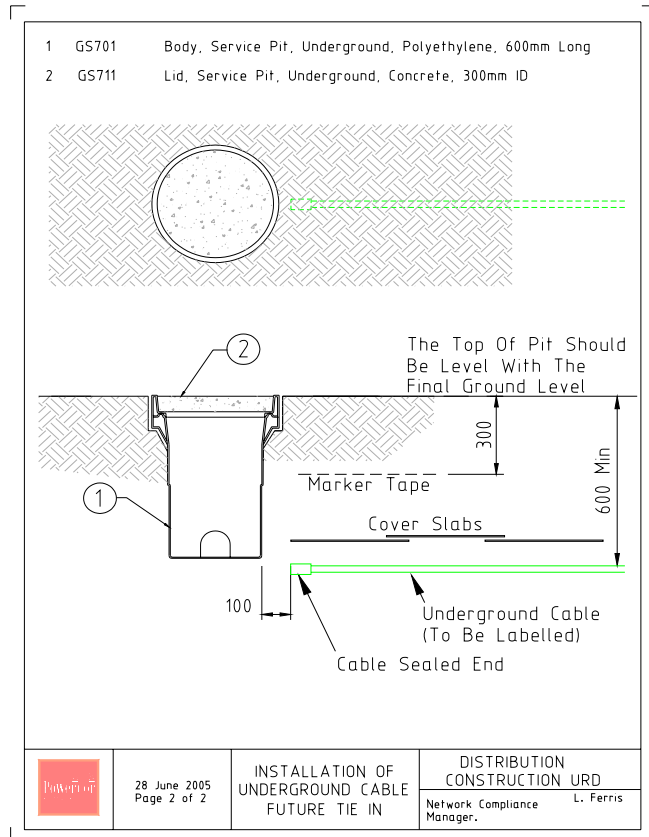

**(attachment g)**

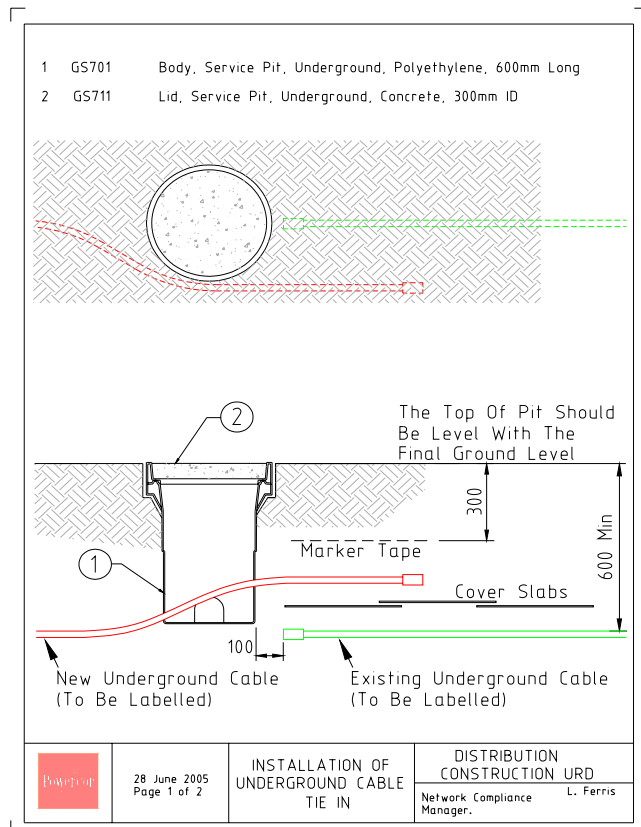

(attachment h)

### Labelling Options for Underground Cables

options - White Marker (Pentel Item # 100) or Plastic Label



(attachment i)



**Alterations / Additions to Assets**

PROJECT TITLE					PM ORDER							
<b>Pole</b>	<b>As Built Details</b>				<b>As Built Details</b>							
	Lis Number											
	Spur Name Pole No											
	Size Strength				m kN							
Material Species				Conc Steel BB SG				Conc Steel BB SG				
<b>X-arm 1</b>	Voltage				66 22 12.7 11 LV				66 22 12.7 11 LV			
	Material				Steel Wood				Steel Wood			
	Location				Pol e	X-arm	Type Stru	N/She d	Pol e	X-arm	Type Stru	N/She d
	Insulator 1											
	Insulator 2											
	Insulator 3											
<b>X-arm 2</b>	Voltage				66 22 12.7 11 LV				66 22 12.7 11 LV			
	Material				Steel Wood				Steel Wood			
	Location				Pol e	X-arm	Type Stru	N/She d	Pol e	X-arm	Type Stru	N/She d
	Insulator 1											
	Insulator 2											
	Insulator 3											
<b>X-arm 3</b>	Voltage				66 22 12.7 11 LV				66 22 12.7 11 LV			
	Material				Steel Wood				Steel Wood			
	Location				Pol e	X-arm	Type Stru	N/She d	Pol e	X-arm	Type Stru	N/She d
	Insulator 1											
	Insulator 2											
	Insulator 3											
<b>Misc</b>	OFC Cable T.V. Fault In											
	Bird Covers etc											
<b>Transformer</b>	Make Serial Number											
	Rating Tap											
	Phasing				RW WB RB RWB				RW WB RB RWB			
	Earthing Type				Common Bonded Separate				Common Bonded Separate			
	HV LV Earth Read				HV LV Ohms				HV LV Ohms			
<b>HV Switch / Fuses</b>	Make / Number of											
	Fuse unit				PF EDO BA F-Tam				PF EDO BA F-Tam			
	Fuse Rating											
	Element Type				K E T				K E T			
<b>LV Switch / Fuses</b>	Make / Number of											
	Fuse unit											
	Fuse Rating											
	Element Type											
<b>Surge Diverters</b>	Make											
	Number of											
	Class				A (Fire) C (non-fire)				A (Fire) C (non-fire)			
<b>Stays</b>	Size Angle				5 8 45 60				5 8 45 60			
	Voltage				66 22 LV				66 22 LV			
	Sidewalk Strut Size				1.8 2.4 3.0				1.8 2.4 3.0			